



# ROTARY RAKE

## USER GUIDE



 **ALPLER**

ATTENTION



**DO NOT  
OPERATE THE MACHINES  
BEFORE READING THIS MANUEL!**

# INDEX

1. INTRODUCTION	3
2. SAFETY RULES	4-6
2.1. REGULAR USE IN AGRICULTURE	4
2.2. GENERAL SAFETY REFERENCES	4
2.3. CONNECT THE MACHINE TO THE TRACTOR	5
2.4. P.T.O. SHAFT DRIVE	5
2.5. TYRES	6
2.6. MAINTENANCE	6
2.7. SECURITY REFERENCES	6
3. PREPARING OF THE MACHINE	7-12
3.1. SPECIAL SAFETY INSTRUCTIONS	7
3.2. ATTACHING TO THE TRACTOR	7
3.3. PTO SHAFT	8
3.3.1. GENERAL	8
3.3.2. P.T.O. SHAFT LENGTH ADJUSTMENT	8
3.3.3. MOUNTING OF THE P.T.O. SHAFT	8
3.4. DISCONNECTING FROM THE TRACTOR	9
3.5. MACHINE ADJUSTMENT	9
3.6. SPRING TINES ARMS-WORK / TRANSPORT SETTING	10
3.7. SETTING THE GUARD RAILS INTO WORK POSITION	11
3.8. SETTING THE GUARD RAIL INTO TRANSPORT POSITION	11
3.9. SWATH CURTAIN	11
3.10. ADJUSTING THE WORKING HEIGHT	12
3.11. TRAFFIC REGULATIONS	12
3.11.1. TRANSPORTING THE SWATHE ON THE ROADS	12
4. MAINTENANCE AND PERIODICAL OVERHAULS	13-15
4.1. SPECIAL SEFETY INSTRUCTIONS	13
4.2. GENERAL	13
4.2.1. SCREWS AND NUTS TIGHTENING MOMENT $M_A$ (STANDARD)	13
4.2.2. TYRES	14
4.2.3. LUBRICATION	14
4.2.4. STORAGE	15
4.2.5. RESTART FOR A NEW SEASON	15
5. SPECIAL CONSTRUCTIONS / ADDITIONAL EQUIPMENT	16
5.1. SUPPORT WHEEL	16
6. WARRANTY	17-18

# WARNING SIGNS & MEANINGS



## CAUTION

This sign warns that the operations described could cause damage to machine, if they are not carried out correctly.



## READ MANUAL FIRST

Read the "Operating and Maintenance Manual" carefully before first start and keep the manual nearest.



## WARNING

This sign warns that the operations described could cause serious lesions or long term health risks, if they are not carried out correctly.



## KEEP CHILDREN AWAY

This symbol expresses to keep the children away against any risk.



Be careful against danger of entrapment.



## DO NOT STAND NEAR THE MACHINE WHILE IT IS WORKING

This symbol expresses not to stand near the machine while it is working to avoid any injury.



Do not carry people or loads on the plough.



Do not open or remove safety shields while the engine is running



## REVOLVING DEVICE

Stay clear of mower knife area as long as tractor engine is running



Max. allowed PTO shaft rotations 540 RPM



Shut off engine and remove key before performing maintenance or repair work.

# 1. INTRODUCTION

Dear Farmer,

Firstly, we congratulate you for your correct preference on the way to efficiency by selecting the brand "ALPLER". As your agricultural partner, we offer you our product in which we combined high quality, low operational cost and effective after-sale service concept.

All of "ALPLER" products are designed for the most efficient and the safest use and tested accordingly in cooperation with the relevant university departments, agricultural establishments and farmers. We request you to read the user manual before the first operation in order to use our product in a more effective manner as well as for product and your own safety. The failures that may result from using the product beyond the instructions for use specified in this manual are not covered by "ALPLER" warranty. "ALPLER" products are manufactured for agricultural utilization purposes only, and our company does not assume any liability against the conditions arising from misuse. Maintenance, repair and operation of our products must be carried out by those who were informed on the relevant and possible dangers.

Enjoy your new product and we wish you productive and fruitful years.

We hope to serve you for a long time...



## CAUTION

If the product owner changes in the future, please submit this manual to the new owner of the product and inform on safety measures.

# 2. SAFETY RULES

## 2.1. REGULAR USE IN AGRICULTURE

- The machine has been designed strictly for regular use in agriculture.
- If the machine was missused for any other purpose, and get damaged during irregular use, manufacturer is not liable for damages caused to the machine. It is the user himself who bears the risk.
- All conditions for work and maintenance, prescribed by the manufacturer, should strictly be considered.
- The machine may only be used, handled and repaired by persons who are appointed to do this and who are aware of the dangers.
- All relevant safety regulations as well as all generally used safety technical, working-medical and traffic regulations should be considered during the work with the machine.
- The manufacturer is not liable for damages, caused to the machine which has been rebuilt by the user, if damages had occurred as a result of the rebuilding.

## 2.2. GENERAL SAFETY REFERENCES

1. Besides the instructions from this booklet take into consideration all generally used safety and accident regulations!
2. Safety and warning decals, placed on the machine, give important instructions for safe work. Take them into consideration for your safety!
3. While driving on public roads, take into consideration traffic signs and regulations!
4. Make sure you become familiar with all devices and elements for handling and with the functions, before starting with the work!
5. Avoid wearing loose-fitting clothes. Clothes should fit tight to the user's body.
6. To avoid danger of fire, keep the machine clean!
7. Before switching on the machine and driving off, make sure there is space near the machine. Make sure your visibility is sufficient!
8. It is prohibited to drive persons on the machine!
9. Implements should be connected according to the instructions, all prescribed devices fastened to the prescribed spots and secured!
10. When disconnecting the machine from the tractor, place it on the flat ground and use support devices!
11. Special attention is needed when you are connecting or disconnecting the implement to the tractor!
12. Always place the charging weights according to the instructions on the provided fastening points!
13. Respect prescribed pay load, axle load and transport dimensions!
14. Transport equipment on machine and tractor is to be tested for traffic safety before each use: lights, protections etc!
15. Starting devices for remote control (wires, chains, bars, etc.) should be secured in a way, that they can not be unintentionally released during transport or work.
16. For driving on the road, prepare and secure the machine according to the manufacturer\*s instructions!
17. Never leave the tractor drivers seat during operation!
18. Always adjust the driving speed to the driving conditions. Avoid fast turning when driving uphill, downhill or across the slope!
19. The performance during driving and the ability of turning is changed, when there are implements connected or mounted to the tractor. Pay attention to sufficient ability of turning and braking!
20. When turning, take into consideration the load which is outside the centre of gravity and/or constant weight of the implement!
21. Connect the imlement only when all safety devices are in position and when the implement is secured!
22. It is prohibited to be in the working and dangerous area of the machine!
23. Stay away from the area of swinging and turning of the machine!
24. Hidraulic flaps, doors etc. may be put in action only when no one is in the swinging area!
25. On all parts of the machine, which are mecanically or hydraulically driven, there is danger of shear and squeeze!
26. Secure the implement before leaving the tractor. Lower the implement completely. Switch off the engine and pull out the ignition key! Disengage the PTO shaft!
27. Nobody is allowed to be between the tractor and the implemant if the vehicle is not secured against movement by a brake or/and by a wedge!

# 2. SAFETY RULES

## 2.3. CONNECT THE MACHINE TO THE TRACTOR

1. Before mounting and/or dismounting the machine to or from three point hitch set the handling device into position that prevents uncontrolled lowering or lifting of the machine!
2. When mounting the machine on three point hitch of the tractor, category of fixing points must be or must be done identical!
3. In the area of 3 point hitch bars there is a danger of injuries being caused by squeezing and of bruises!
4. When operating outside lift-control of three point hitch, don't stay between tractor and machine!
5. When machine in transport position, adjust and lock side movement of three point hitch!
6. When driving on the road with lifted machine, insure the lever of hydraulic control against unintentional drop!

## 2.4. P.T.O. SHAFT DRIVE

1. Use only P.T.O. Shafts prescribed by the manufacturer!
2. PTO shaft - protection tubes and protection pots, driveshaft protection on the tractor, and on inlet shaft on the machine must be on their places and in good condition!
3. Take care about the prescribed P.T.O. Shaft tube overlap in transport and working position!
4. P.T.O. Shaft can only be mounted when the P.T.O. Shaft connection and engine are switched off and the ignition key is pulled out!
5. When using the P.T.O. Shafts with overload and/or free-wheel clutch, which are not covered by a protection on the tractor, put the overload or the free-wheel clutch on the machine side!
6. Always pay your best attention to proper mounting and securing of the P.T.O. Shaft!
7. Secure the P.T.O. Shaft protection against rotating by a chain!
8. Before switching on the P.T.O. Shaft make sure, that the selected RPM and rotating direction of the tractor connection match with the allowed RPM and rotating direction of the machine!
9. When using the P. T.O. shaft pay attention that the number of rotations is independent of driving speed and rotation direction of reverse driving!
10. Make sure that nobody is in the area of danger of the machine before switching on the P.T.O. Shaft!
11. Never switch on the P.T.O. Shaft when the engine is switched off!
12. When working with the P.T.O. Shaft nobody is allowed to be in the area of rotating P.T.O. Shaft.
13. Always switch off the P.T.O. Shaft when the angle deviation gets too big or when you do not need it!
14. **Attention!** After having switched off the P.T.O. Shaft the danger of rotating heavier parts remains. Do not get close to the machine until it comes to a complete standstill. You can start to work only when the rotation is completely stopped.
15. Cleaning, lubrication or adjusting of the machines, driven by the P.T.O. Shaft, or a P.T.O. Shaft itself, can be done when the engine is switched off and the ignition key is pulled out!
16. Disconnected P.T.O. Shaft is to be put onto provided holder!
17. When PTO Shaft pulled from the tractor, push the protection cap back on the drive shaft of the tractor!
18. Repair all damages of the P.T.O. Shaft before using the machine!

# 2. SAFETY RULES

## 2.5. TYRES

1. While working with tyres make sure that the machine is safely placed and secured against rolling off (wedge).
2. Mounting tyres requires sufficient knowledge and tools according to regulations!
3. Repair works on tyres are allowed to be performed by professionals with suitable tools only!
4. Check up the tyre pressure regularly! Consider the tyre pressure according to regulations!

## 2.6. MAINTENANCE

1. Maintenance, repairs, cleaning and disturbance removing may only be executed when the drive and the engine are switched off and the ignition key is pulled out!
2. Check nuts and screws regularly to be sure that they are tightened enough. If not tighten them!
3. If you perform any maintenance on the lifted implement, always secure the implement by a suitable holder.
4. Use adequate tools and gloves when replacing machine parts with sharp edges!
5. Store properly oils and greases!
6. Before repairs on electrical equipment are started, switch off the electrical current – remove the fuse!
7. If safety devices succumb to usage, must be checked regularly and replaced in due time!
8. When welding on the tractor or on machine which is mounted on the tractor, disconnect the cable from battery and from generator!
9. Use only genuine spare parts, they will provide a long lifetime of the machine!
10. When filling in the gas, use for filling in exclusively azote. Danger of EXPLOSION!

## 2.7. SECURITY REFERENCES

Alpler machines are equipped with all safety devices which are prescribed by law.

However it is not possible to protect all danger spots on the machine, regarding functionalism of the machine itself. On the machine there are decals with corresponding informations about danger in that area. Decals are yellow and black colour.



Read carefully text of safety decals, check on the machine where are they to be found, because there are danger areas.



# 3. PREPARING OF THE MACHINE

## 3.1. SPECIAL SAFETY INSTRUCTIONS



- When performing check up, maintenance repair and mount works always switch off the P.T.O.shaft. Switch off the engine and pull out the ignition key. Secure tractor against movements.
- Maximum number of rotations is 540 rpm.
- Nobody is allowed to stay between the tractor and the machine when lifting or lowering the swather with tractor hydraulics.
- Make sure nobody is in the danger area of the swather before switching on the P.T.O. shaft. High injury risk!
- Pay attention to use protections according to regulations when working or driving on the road. Mount the light equipment and check its functioning.
- Never leave the driver seat during working.

1. Before connecting or disconnecting the machine to the three point hydraulic hitch, set the handling device into the position which prevents unintentional lowering or lifting of the three point hitch!
2. Connecting and disconnecting the swather requires special attention!
3. In the area of three point hydraulic hitch bars there is danger of injuries being caused by squeezing and of bruises.
4. The machine is constructed with three pont hydraulic hitch bars-connections of the 2<sup>nd</sup> category.

## 3.2. ATTACHING TO THE TRACTOR



- Pay attention that nobody is between the tractor and the machine when connecting the machine to the tractor.
- Make sure that the machine has sufficient driving capacity during the drive. (ballast weights)

- Mount the lower hydraulic bar (1) and secure it with pin (2).
- Set the upper bar (3) and secure the bolt with pin (4).

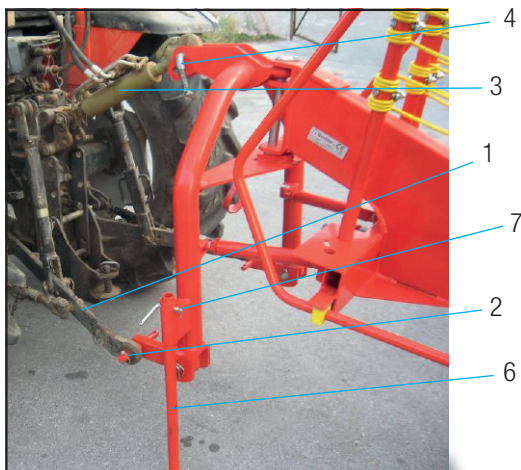

Figure 1

- Lift the support leg (6) and secure it in upper position with pin (7). Do not remove the support leg!

- Lowering speed of the 3 point hitch is to be adjusted by stifler so that the swather lowers onto the ground slowly.

# 3. PREPARING OF THE MACHINE

## 3.3. PTO SHAFT

### 3.3.1. GENERAL



- After connecting the machine to the 3 point hydraulic hitch bar switch off the engine and pull out the ignition key. Secure tractor against movement!

P.T.O. shaft is constructed with overload safety clutch. It secures the tractor and the machine from damages. Do not interfere in overload safety clutch settings. Loss of warranty rights.

If overloaded the rotation movement is limited with pulsative slip of the clutch.

- To prevent the wear out of the overload safety clutch you must switch off the P.T.O. shaft immediately.
- Compare the measured value of rotation moment RM of the overload safety clutch with values in the table. If the values deviate, contact SIP seller.

### 3.3.2. P.T.O. SHAFT LENGTH ADJUSTMENT



- Switch off the P.T.O. shaft when performing check up, maintenance, repair and mount works. Switch off the engine and pull out the ignition key. Secure the tractor from movement.
- Nobody is allowed to stay between tractor and machine when lowering the swather with the hydraulics.
- Danger of material damage: Do not lower the swather with the hydraulic before the P.T.O. shaft length is adjusted.

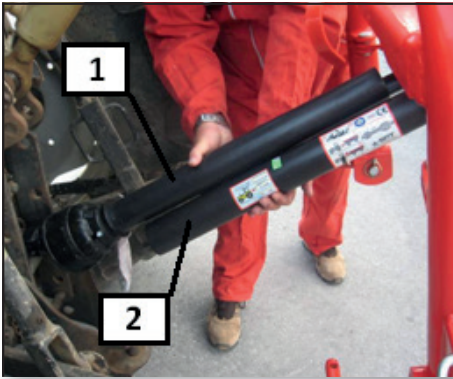

Figure 2

- To adjust the length of the P.T.O. shaft pull the both halves apart.
- Place the P.T.O. shaft halves on the machine's side (1) and on the tractor's side (2).
- Overload safety clutch must be mounted on the machine's side!
- Set the machine with 3 point hitch to the shortest position of the P.T.O. shaft.
- Hold both halves together and measure out the right length.
- For further measurements and adjustments use the instructions of the P.T.O. shaft manufacturer.

### 3.3.3. MOUNTING OF THE P.T.O. SHAFT

- Secure the protection tube (3) against rotation. Secure the protection tube on tractor side with chain (2).
- Check the turn and space area of the P.T.O. shaft. P.T.O. shaft touching the tractor or the machine may cause damage (touch with 3 point hydraulic hitch bar, machine connection).

# 3. PREPARING OF THE MACHINE

- Grease the P.T.O. shaft with multipurpose grease in time intervals shown in the figure 5. Consider the instructions of the P.T.O. shaft manufacturer.



- Use the grease on vegetable basis.

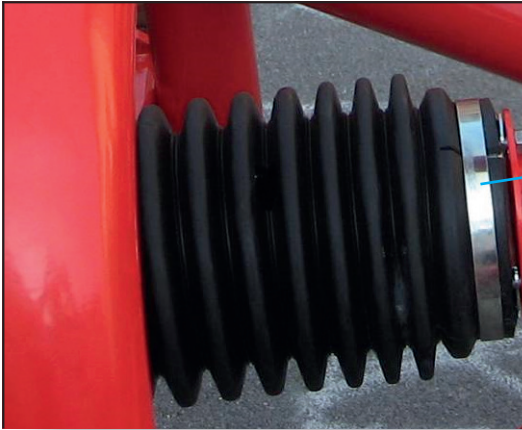

Figure 3



Figure 4

## 3.4. DISCONNECTING FROM THE TRACTOR



- Pay attention to put the swather on a flat and solid ground.
- Nobody is allowed to stay between the tractor and the machine when lifting or lowering the machine with 3 point hydraulic hitch.
- Pay attention to the following safety instructions.



Figure 5

- Choose flat, dry and firm enough ground to deposit machine.
- Lower the support leg and secure it with safety device.
- Lower the machine and make sure that it is placed steady.
- Disconnect the P.T.O. shaft (1) and put it on the holder (2).
- Loosen and disconnect the upper lever.
- Disconnect the lower levers.

# 3. PREPARING OF THE MACHINE

## 3.5. MACHINE ADJUSTMENT



- Perform the repair work, maintenance, cleaning and stopping works only with the switched off drive and stand still engine! Remove the ignition key.
- Maximum P.T.O. shaft rotation is 540 rpm.
- Optimal P.T.O. shaft rotation is between 350 and 450 rpm.
- It is forbidden to stay in the working area of the machine.
- Danger warning of substance eject behind the machine.
- It is forbidden to climb on the machine.
- Protections must be in protective position while working.



Figure 7

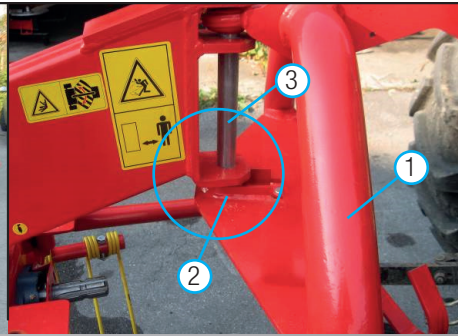

Figure 8

Lower the swarher slowly! Set the control lever of the 3 point hitch hydraulic to the »low« position, the so-called swimming position. The cylinder of holder (3) must lay at the end (2) of the hitch bar (1) fender pile. Set the swather with upper lever to horizontal, slightly forward (1) inclined position. Spring tines should touch the ground softly.

## 3.6. SPRING TINES ARMS-WORK / TRANSPORT SETTING



- Mounting the spring tines arms from transport to work position or from work to transport position pay attention not to stretch unintentionally the spring safety pins. Risk of accident!
- Mount the spring tines arms with the switched off engine only! Remove the ignition key.
- Always mount the pins against the rotor's rotation direction.

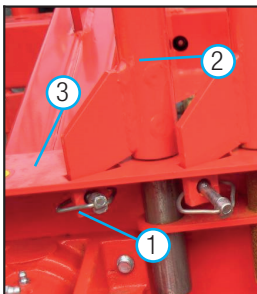

Figure 9

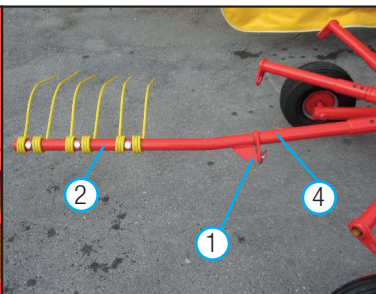

Figure 10

### Work position setting:

- Pull out the pin (1) from the spring tines arm (2).
- Remove the spring tines arm (2) from the transport holder (3) and put it on the rotor pipe (4).
- Secure the spring tines arm (2) with pin (1).

### Transport position setting:

- Pull out the pin (1).
- Pull out the spring tines arm (2) and put it in the transport holder (3), spring tines must be turned inwards.
- Secure the spring tines arm (2) with pin (1).

# 3. PREPARING OF THE MACHINE

## 3.7. SETTING THE GUARD RAILS INTO WORK POSITION

Guard rails (1) are additionally secured for transport. To set the guard rails into working position follow the next steps:

- Pull out the quoin (2) by the string;
- Lower the guard rail (1) into working position so that the quoin (2) locks in.

## 3.8. SETTING THE GUARD RAIL INTO TRANSPORT POSITION

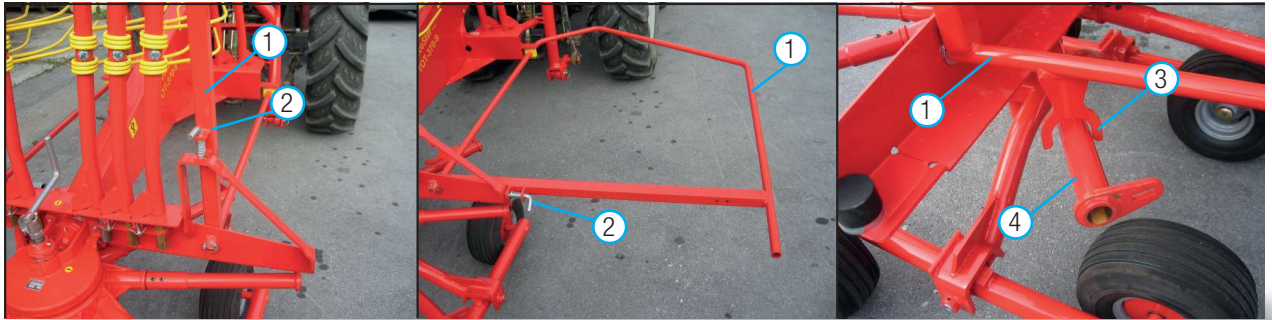

Figure 11 A

Figure 11 B

Figure 11 C

- Pull out the quoin (2) by the string;
- Lift the guard rail (1) into transport position and make sure that the safety device (3) embraces the rotor's arm.
- Guard rail (1) is in transport position when the quoin (2) sticks once again.

## 3.9. SWATH CURTAIN

For wide or narrow swaths set stagelessly the swath curtains to rotor.

- Undo the fixing screw (1).
- Move the swath curtain (2) to selected position.
- Tighten the fixing screw (1) again.
- Adjust the swath curtain deviation to the fodder quantity.
- Much fodder = big deviation
- Few fodder = no deviation needed
- Adapt the driving speed to the working picture = clean swathing if the swath is well formed.

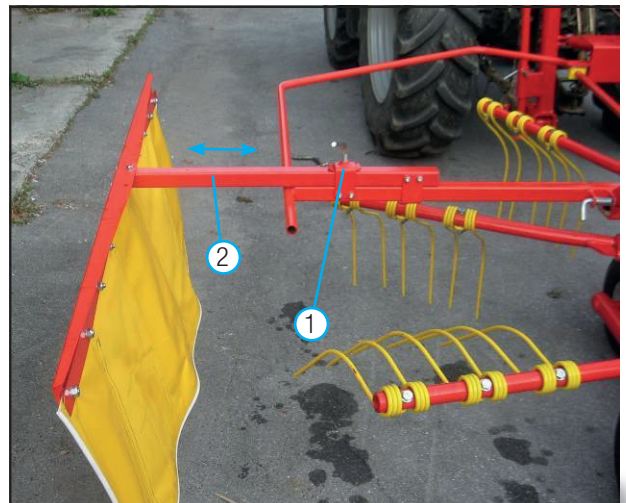

Figure 13

# 3. PREPARING OF THE MACHINE

## 3.10. ADJUSTING THE WORKING HEIGHT

Adjust the right height of the swather with the lever (1). Adjusted working height depends on driving speed and fodder condition.

Loosen or tighten the nut (2) to adjust the right friction in order to prevent the unintentional rotation of the lever (1).



- With bigger distance between the spring tines you can not swath the fodder completely.
- With smaller distance between the spring tines there is a danger of fodder soiling, sod damage and high wear out of the spring tines.

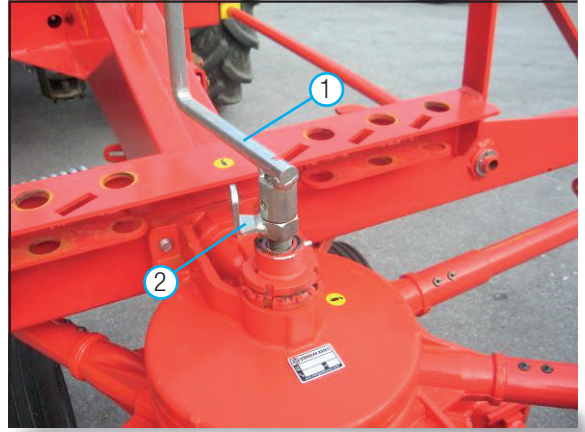

Figure 14

## 3.11. TRAFFIC REGULATIONS

### 3.11.1. TRANSPORTING THE SWATHE ON THE ROADS

- When driving on public roads and paths consider the local traffic regulations.



- Pay attention to have the rear window of tractor's cabin closed before lifting the swathe. The guard rails may cause damage if not secured

# 4. MAINTENANCE AND PERIODICAL OVERHAULS

## 4.1. SPECIAL SEFETY INSTRUCTIONS

- Repair works, maintenance, periodical overhauls, cleaning and elimination of functional disturbances must be performed with the switched off drive and stand still engine! Remove the ignition key!
- Do not use excessive quantities of oil and grease. Be friendly to nature.
- When injured with splashed oil find medical help immidiately.
- Consider other safety instructions to prevent damages and accidents.

## 4.2. GENERAL



- To insure faultless working of the machine and to reduce the wear out always consider the maintenance instructions and periodical overhauls. This includes cleaning, greasing and lubricating of built in parts and components.

### 4.2.1. SCREWS AND NUTS TIGHTENING MOMENT $M_A$ (STANDARD)

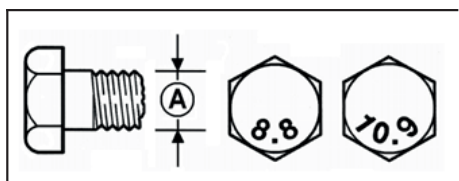

A = size of coil

- After the first start and few hours of working check the tightness of nuts and screws, tighten them if needed.
- Check up regularly (approx. every 50 hours)!

A Ø	8.8	10.9	12.9
	$M_A$ (Nm)		
M 5	5,9	8,7	10
M 6	10	15	18
M 8	25	36	43
M 10	49	72	84
M 12	85	125	145
M 14	135	200	235
M 16	210	310	365
M 20	425	610	710
M 24	730	1050	1220
M 27	1100	1550	1800
M 30	1420	2100	2450

# 4. MAINTENANCE AND PERIODICAL OVERHAULS

## 4.2.2. TYRES



- To mount tyres sufficient knowledge and regulation tools are required.
- Repair works on tyres are allowed to be performed by professionals with proper tools only.
- Place the machine on flat and solid ground. Secure it with wedges against unintentional rolling off.
- Check the tyre pressure regularly.

## 4.2.3. LUBRICATION

In the figure 18 all the lubrication spots are marked. Long life of the swather is achieved if the time intervals shown here are met.



- Repair works, maintenance, periodical overhauls, cleaning and elimination of functional disturbances must be performed with the switched off drive and stand still engine! Remove the ignition key!
- Use the grease on vegetable basis.

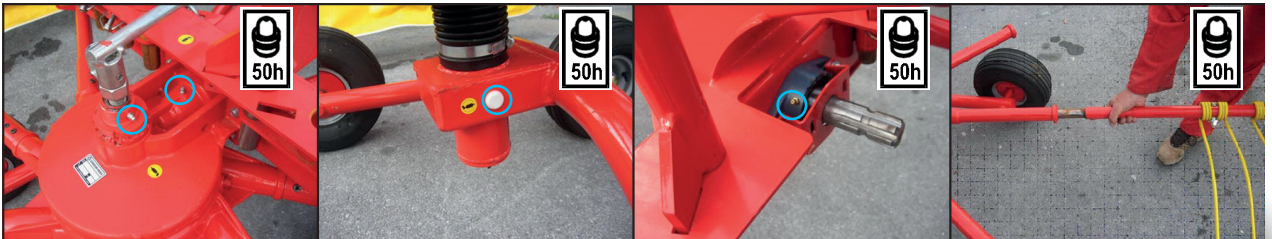

Figure 18



Figure 18/2

- Mandatory check the oil level before the operation, unscrew the screw plug and check the level of A, which must extend to the lower edge of the stud. Once a year to control the level and refill oil SAE 90 EP, if necessary.
- Draining the possible odvitju threaded pin B, which is located at the bottom of the gear
- Mandatory, if necessary to change oil in gear repair intervention.



- Use the grease and oil on vegetable basis.



# 4. MAINTENANCE AND PERIODICAL OVERHAULS

## 4.2.4 STORAGE

1. Place the machine in a dry place. Not near the mineral manure storehouse.
2. Clean the machine inside and outside thoroughly. Dirt holds moisture and causes rust. Cleaning with high pressure cleaner is not recommended.
3. Check flexible parts such as stay wires, joints and other, demount and clean them, check the wear out. Replace with spare parts if needed.
4. Lubricate all the parts of P.T.O. shaft connections.
5. After cleaning grease the machine thoroughly.
6. Grease the bearing of P.T.O. shaft protection to reduce agglutination.
7. Repair the paint damage, protect the bright surfaces with a remedy for rust.
8. Grease the contact area on the spring tines arm and rotor plug.
9. Reduce the tyre pressure to discharge it and protect tyres from sun, grease and oil.
10. Make a list of necessary spare parts and order them in time. It easier for SIP-sellers to order and deliver them out of season. Beside that the machine is fully prepared and ready for work in the new season.

## 4.2.5. RESTART FOR A NEW SEASON

1. Wipe the oil and grease used for the conservation of the machine.
2. Lubricate the machine thoroughly to eliminate the possible condensation moisture from bearings.
3. Check the tyre preassure.
4. Check the level of lubricant in the gearings, refill it if needed.
5. Check and tighten all nuts and screws.
6. Check all the settings on the machine and re-set them if needed.
7. Check the overload safety clutch of the P.T.O. shaft, if the metal parts of slide lining become loose (look inside).
8. Read carefully the work and safety instructions again.

# 5. SPECIAL CONSTRUCTIONS / ADDITIONAL EQUIPMENT

## 5.1. SUPPORT WHEEL

Mount the support wheel on the swather to make better copying of the swath surface possible. While working the purpose chain must be set loose on the upper connection to enable adaptation of the swather with the support wheel.

- Repair works, maintenance, periodical overhauls, cleaning and elimination of functional disturbances must be performed with the switched off drive and stand still engine! Remove the ignition key!
- Set the support wheel position outside the rotor area – check it in lifted position!
- For transport the purpose must be fixed, if using chain (4) it must be replaced with fixed top link!

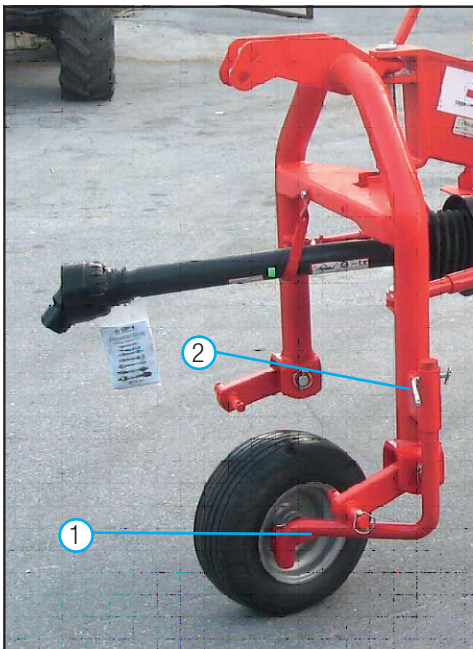

Figure 19A

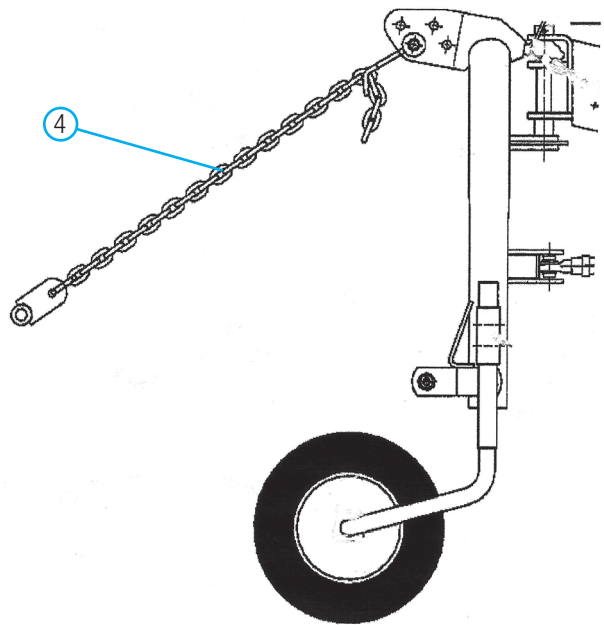

Figure 19B

### Mounting the support wheel

- Montage the supporting wheel (1) onto the support leg position.
- Set the desired height and fix the wheel (1) with latch support (2).
- Connection between the upper hitch and tractor with chain (4).



- The purpose chain must be set loose to enable adaptation of the swather with the support wheel and the lifting of the swather.

# 6. WARRANTY

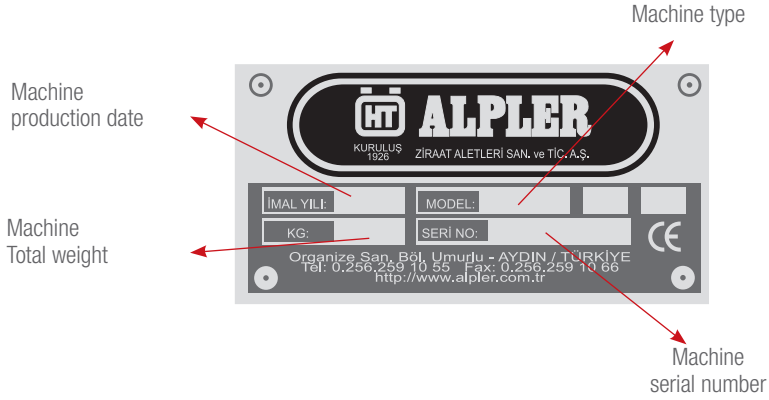

Use original spare parts in ALPLER branded products. The customer will be responsible for the problems that occur due to not using original spare parts. The Rotary Rake will not be covered by the warranty when non-original parts are installed on the machine, additional equipment is attached to the machine or it is used after removing standard parts.

While ordering spare parts, for the codes beginning with '0', machine serial number together with the part code should be provided. For other codes, it is not necessary to provide the Rotary Rake serial number.

Label information is important for identifying the machine and for spare part orders. As a measure against the illegibility of the label due to deformation or its loss, label information on the machine should be written literally in the corresponding fields of the following label picture, and it should be retained.

Our Rotary Rakes are **warranted for 2 years** for faults that may occur due to material, workmanship and mounting errors.

Faults resulting from improper use are not covered by the warranty. The average lifetime is 10 years.

# 6. WARRANTY

## WARRANTY CERTIFICATE

Warranted by ALPLER for a period of two years

BRAND: ALPLER  
PRODUCT TYPE:  
MODEL:  
SERIAL NUMBER:  
DATE OF PRODUCTION:

### Seller's

Title:.....  
Address:.....  
Phone:.....  
Fax:.....  
Invoice Date:.....

Signature & Seal

# NOTES



Exports to 75 countries  
on 5 continents.

 **ALPLER**

**ALPLER AGRICULTURAL MACHINERY**

Umurlu Organize Sanayi Bölgesi Umurlu-AYDIN / TÜRKİYE

Tel: +90 (256) 259 1055 Fax: +90 (256) 259 1066

Web: [www.alpler.com.tr](http://www.alpler.com.tr) E-mail: [alpler@alpler.com.tr](mailto:alpler@alpler.com.tr)